

Typ / Type : DVW/DHW 450-8 E		Art.-No. : A26-45015 / A36-45015	
U	230V (50Hz)	Δp_{fa} min	-- Pa
P ₁	0,15 kW	ΔI	-- %
I _N	0,86 A	I _A / I _N	1,5
n	605 min ⁻¹		IP54
C _{400V}	3 μ F		01.024
t _R	70 °C		26 kg

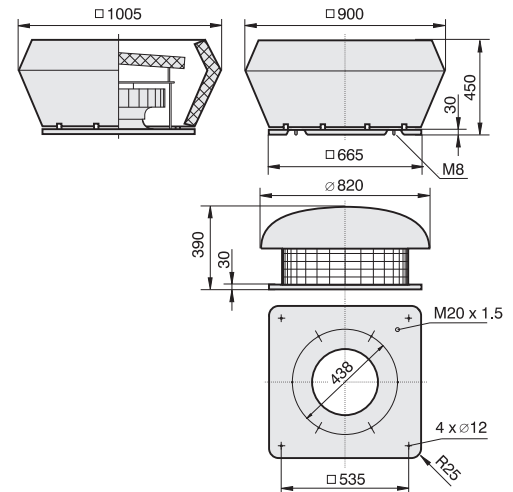

LW _{Arel} A-bewertet bei V=0,5*V _{max} LW _{Arel} A-weighted at V=0,5*V _{max}		f _M [Hz]						
		125	250	500	1K	2K	4K	8K
LW _{A5} [dB(A)]	Ansaugseite / inlet side	-18	-13	-12	-9	-7	-14	-21
LW _{A6} [dB(A)]	Ausblasseite / outlet side	-16	-10	-6	-5	-6	-13	-22